

GENERAL ASSEMBLY INSTRUCTIONS FOR GARAGES WITH ROOFING

This brochure has been prepared for all our garages with roofing.
The drawings may differ from the garage you have purchased.



WOODLANDS

QUALITY CABINS

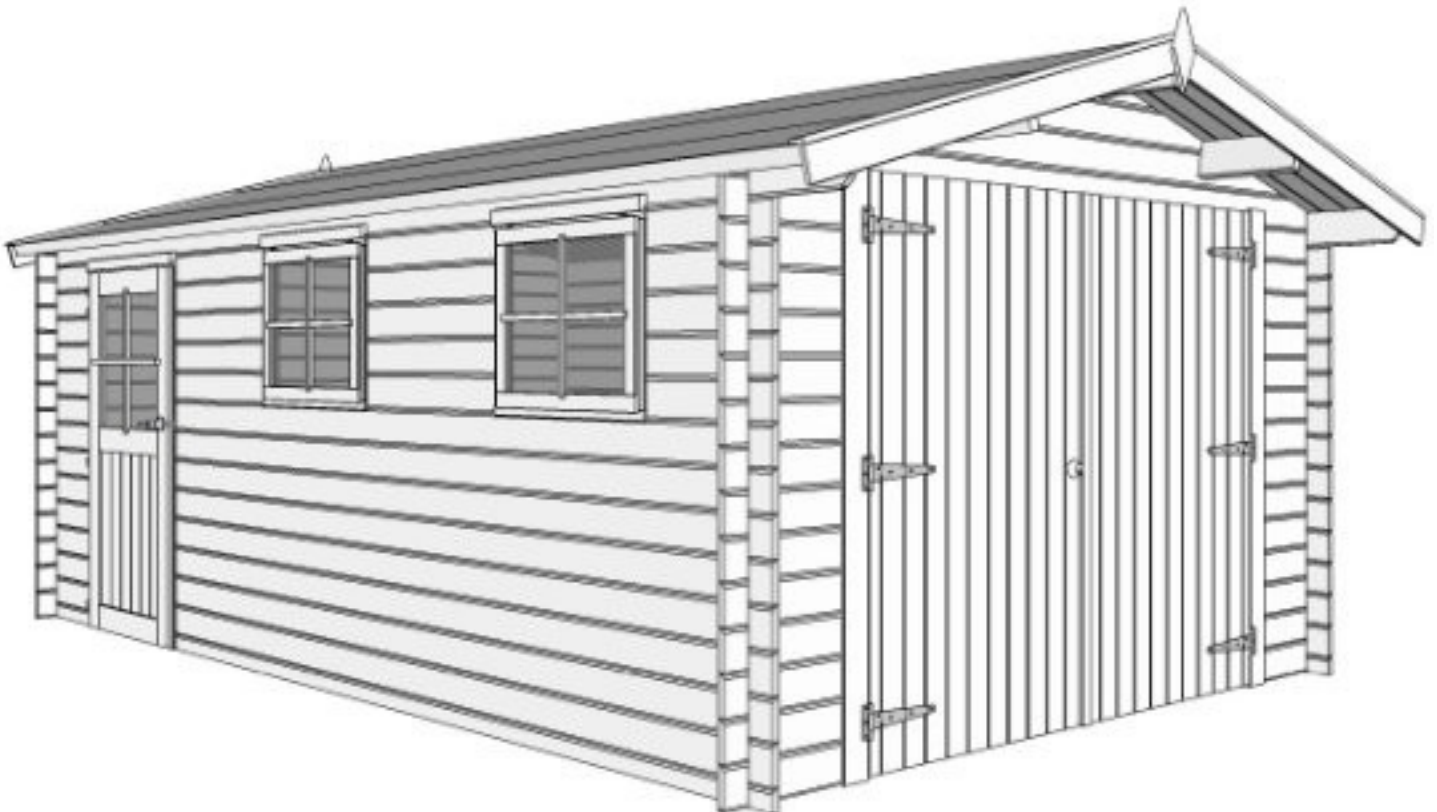

GENERAL ASSEMBLY INSTRUCTIONS FOR LOG CABINS WITH GABLE ROOFS WITH ROOFING

Congratulations on the purchase of your garage.

If you read the assembly instructions carefully, you will enjoy your purchase for many years to come.

IMPORTANT!

Before starting the assembly, we would like to provide you with some important information that deserves your attention.

A I TREATMENT Did you purchase a garage made from an untreated natural product? This type of wood must be treated to ensure a long lifespan. It is best to seek advice from a specialist in the field when choosing your treatment product and maintaining your garage. Only use products that penetrate the wood and protect it against moisture, weather, insects and fungi. Do not use products that are so viscous that they prevent a good connection between the tongue and groove and the corner joints. You only have the opportunity to treat the tongue and groove **before** assembly. It is very important **to treat** all parts **on all sides**. This means you must also treat **the inside of** the garage.

A 2 TREATMENT Did you purchase a pressure-impregnated garage? Gardenas wax impregnation significantly extends the life of your product and provides **temporary** protection against moisture. After the first summer season, you will need to apply an extra protective layer of stain or other paint. This will prevent the wood from splitting and warping. It is best to seek advice from a specialist in the field when choosing your treatment product and maintaining your garage. Only use products that penetrate the wood and protect it against moisture. The pressure impregnation itself protects the garage against rot, mould and insects. The treatment product should therefore only be water-repellent and suitable for outdoor use (= UV-resistant).

B FOUNDATION It is best to install a **waterproof** concrete base. It is extremely important that your garage is level and remains so. Bear in mind that if your structure is not level after installation, cracks and deformations may occur in the garage. Ensure that ground moisture and other moisture cannot penetrate the wood by providing adequate ventilation in the garage and treating **the inside of** the garage against moisture. Seal the joint between the garage and its base with silicone (not included). Anchor all walls to the base (e.g. with L-brackets, not included) to protect against stormy weather.

C UNPACKING Unpack the parts of your garage from the packaging two days before assembly, but keep them sheltered from rain. This will allow the wood to acclimatise to ambient humidity. Now carry out a full check using the enclosed parts list. Material complaints will not be accepted if the parts have been painted. Complaints must be received by us no later than 8 days after delivery.

D Wood is a natural product. This means that slight variations may occur. What are **acceptable** variations?

- Knots,
- Fallen knots no larger than a thumb,
- Fallen knots or slight damage to the edges (tongue and groove) if coverage is guaranteed during assembly
- Discolouration in the wood,
- Straight cracks that do not split the log, splitting cracks no longer than 12 cm,
- Resin pockets of max. 5 cm,
- Wood that is slightly bowed, if assembly remains possible.

E Ensure that your storage unit is **anchored** to its base (e.g. L-brackets, not included).

F To prevent splitting, we recommend pre-drilling with a drill bit smaller than the diameter of the screw.

G If a part is damaged during assembly, or are you having trouble figuring it out? Our after-sales service is at your disposal:

- during office hours by telephone: +32 (0)52 21 95 71
- by fax: +32 (0)52 22 09 03 or
- by email sav@gardenas.be
- If you notice any damage to the package, please let us know within 48 hours.

After you have checked the accompanying parts list, you can start assembling.
What do you need? A saw, a try-square, a piece of auxiliary wood, a screwdriver (preferably battery-powered or electric), 2 ladders, a rubber mallet, a drill, silicone. At least 2 adults are required for assembly. Keep children and pets away during assembly.

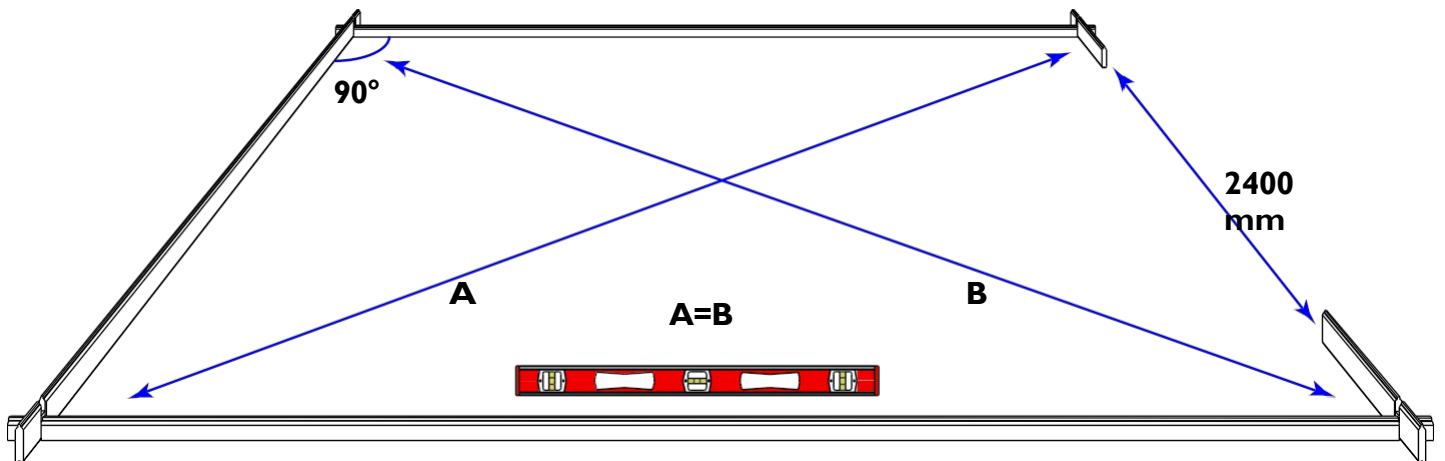
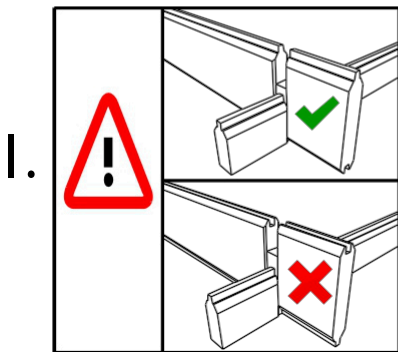
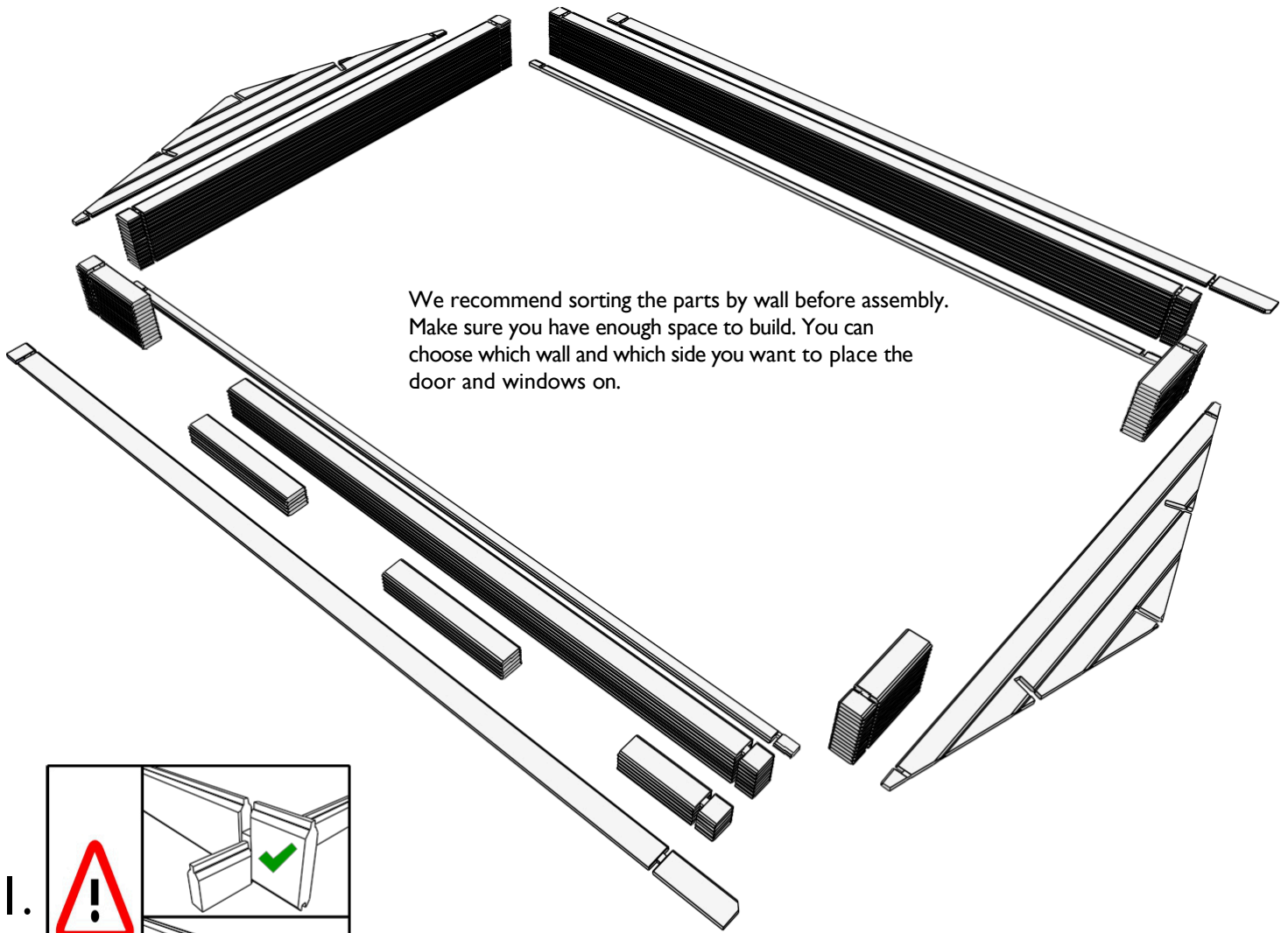

2.

If the door is not in the centre of your garage, you can choose which side to place the door on. **Please note:** first mount the **iron angle brackets to the garage and the base**, then **saw**. The piece you saw off is waste. **Never** mount this above the door!

For further assembly, also consult the wall plans in the parts list. To keep everything square, you must anchor **each** bottom log to the base using angle brackets and concrete plugs (not included). Gardenas dealers sell special storm bracing for this purpose.

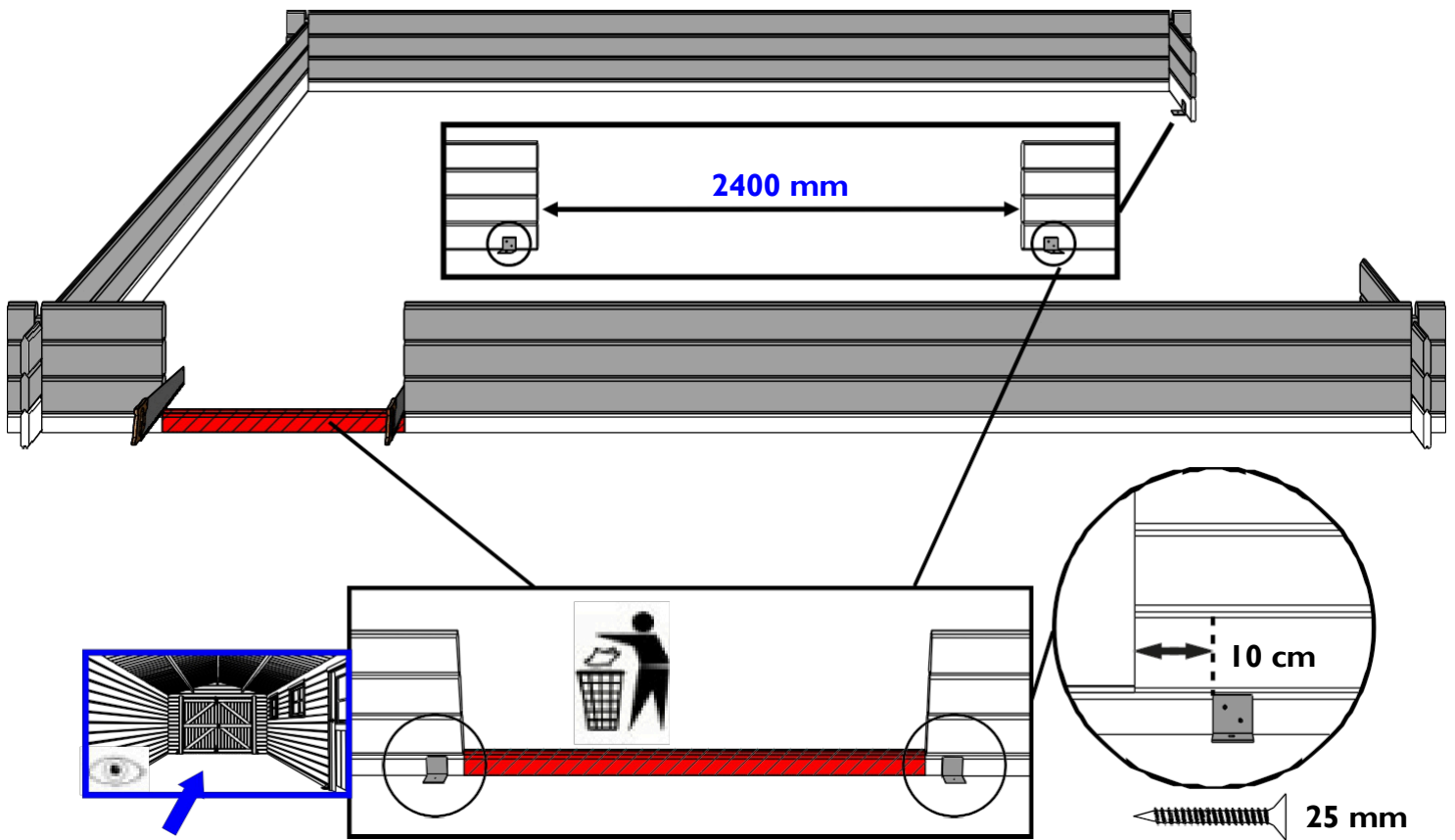
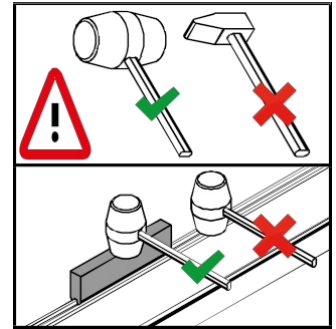

If a warped/crooked log does not fit:

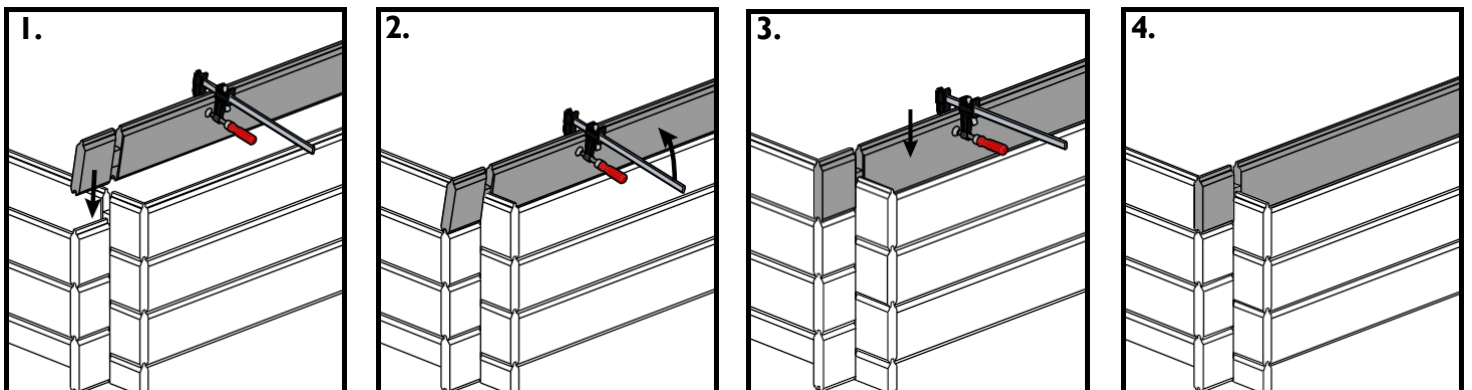

3.

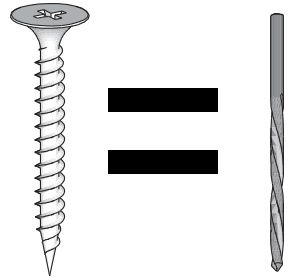
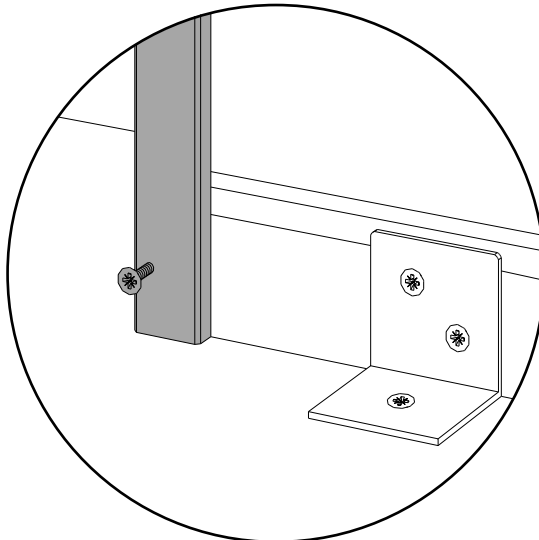
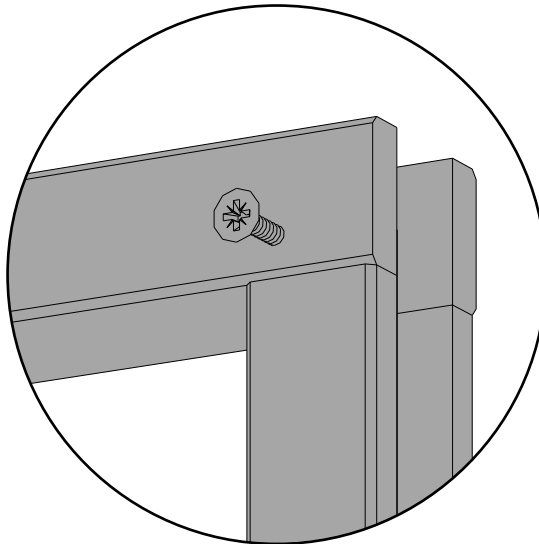
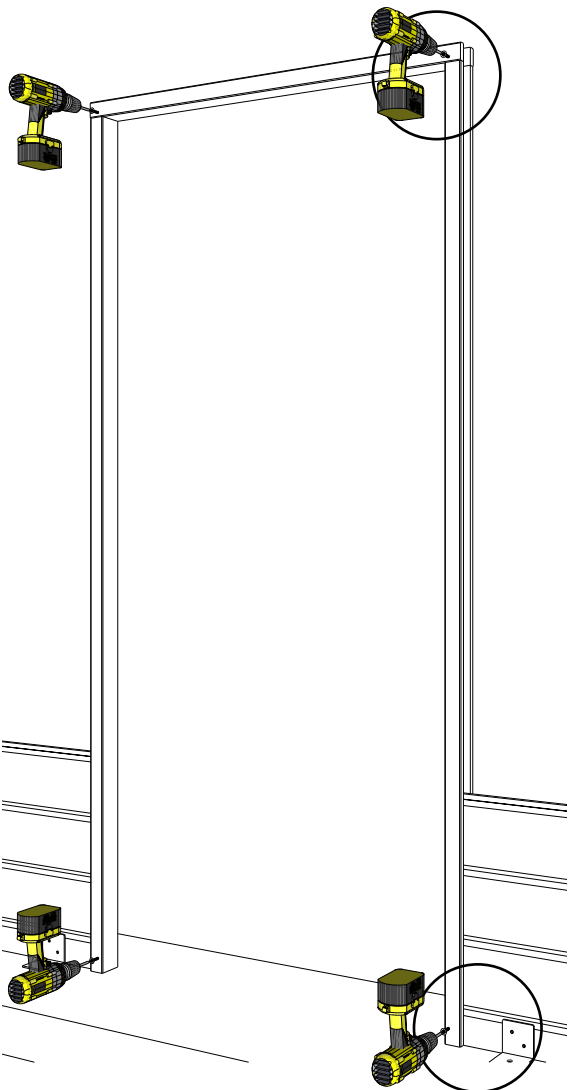
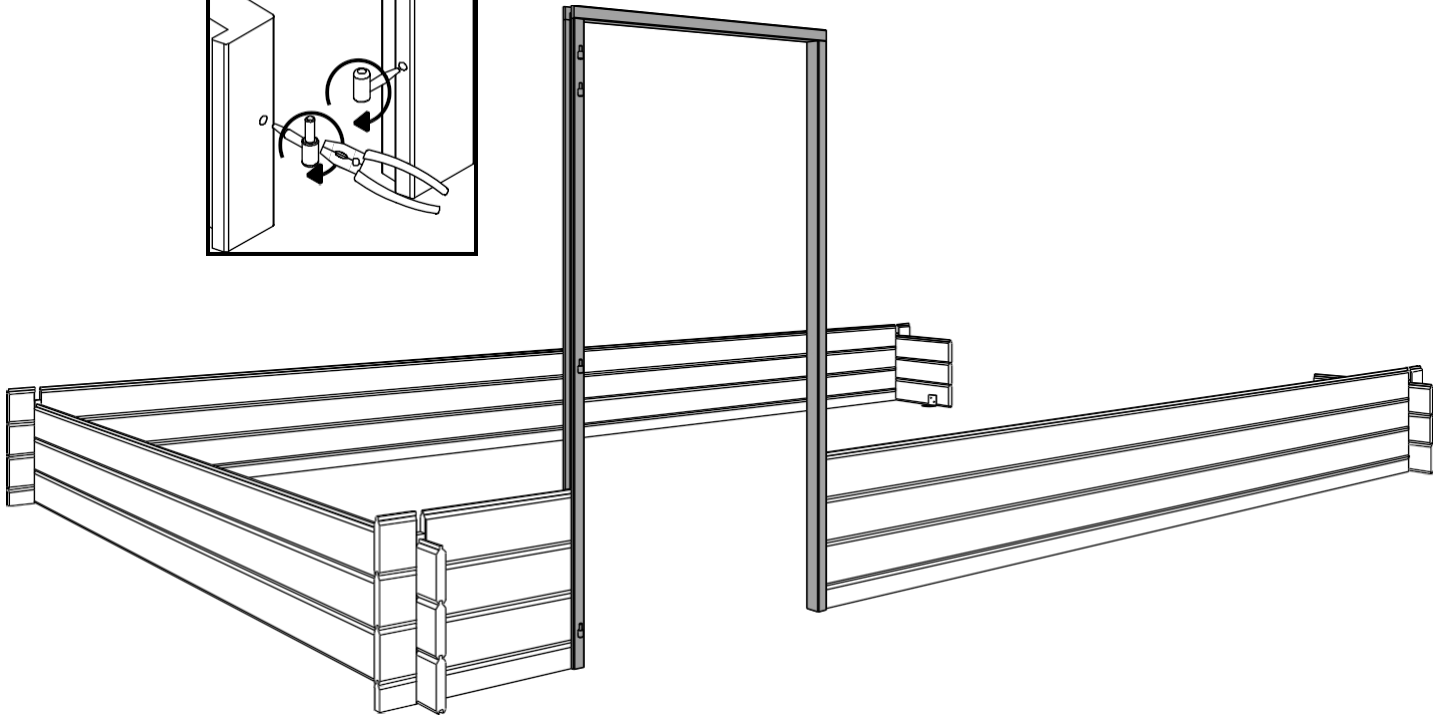
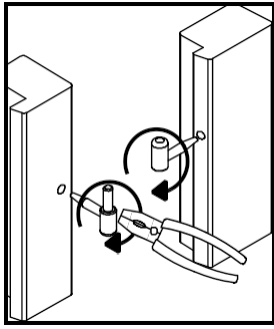

Screw = Pre-drill!
To prevent the wood from splitting when screwing, always pre-drill with a drill bit with a diameter equal to the diameter of the screw core.

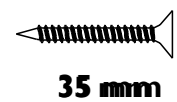

35 mm

4.

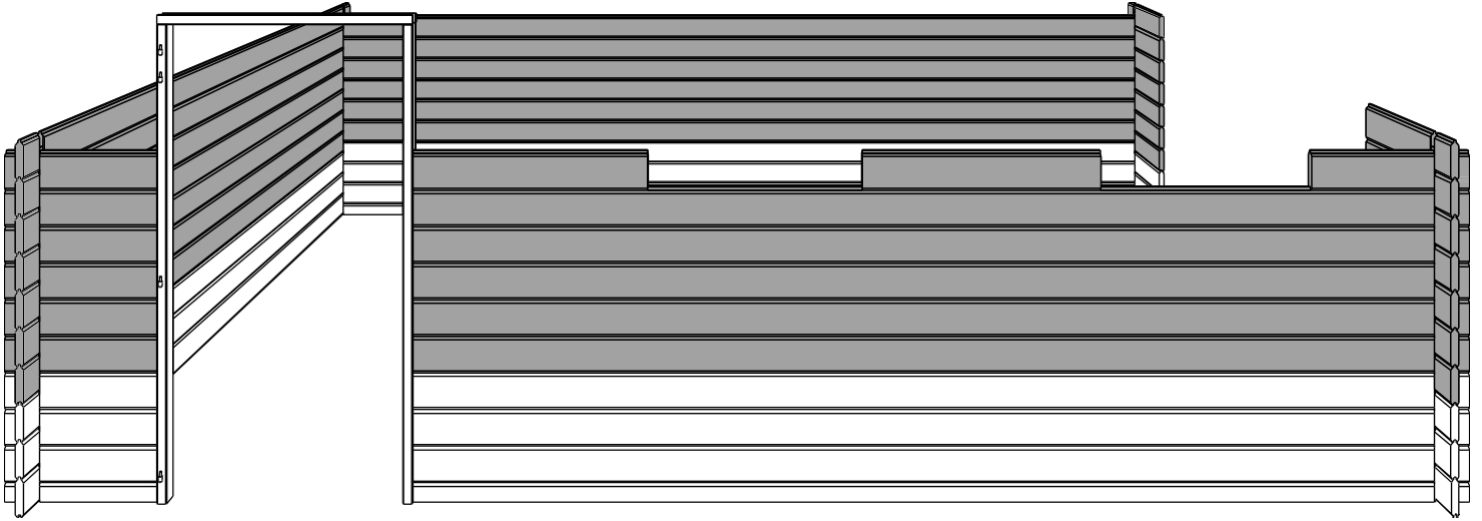

5.

Opening window

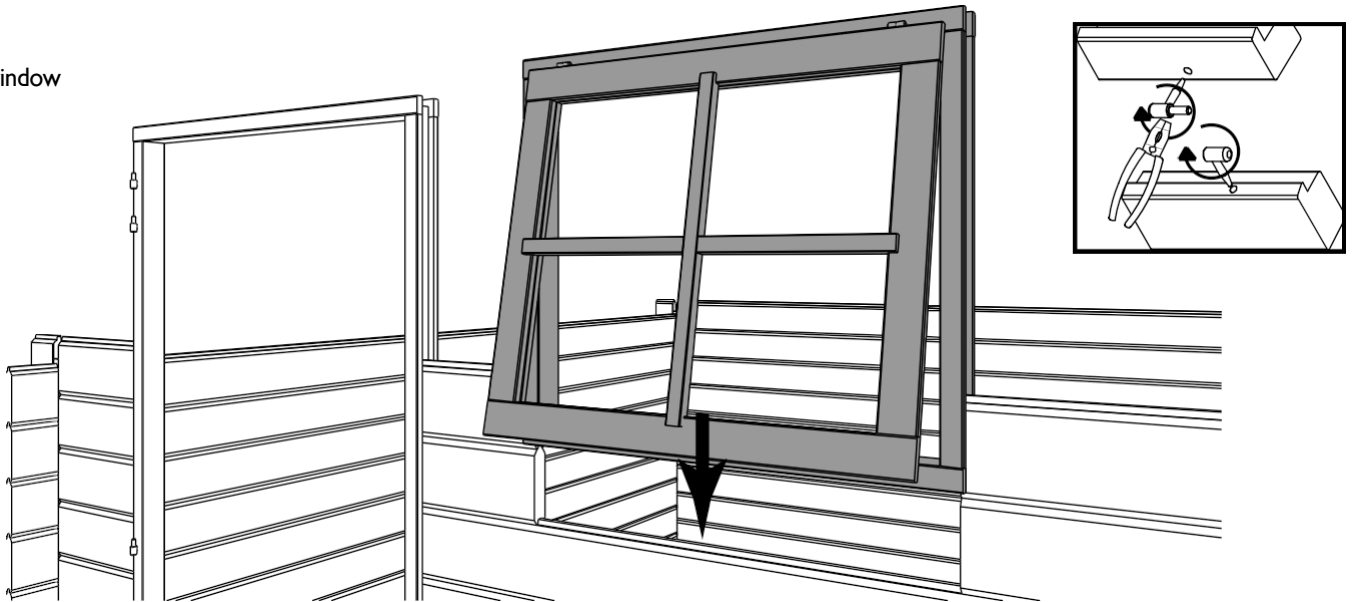

Fixed window

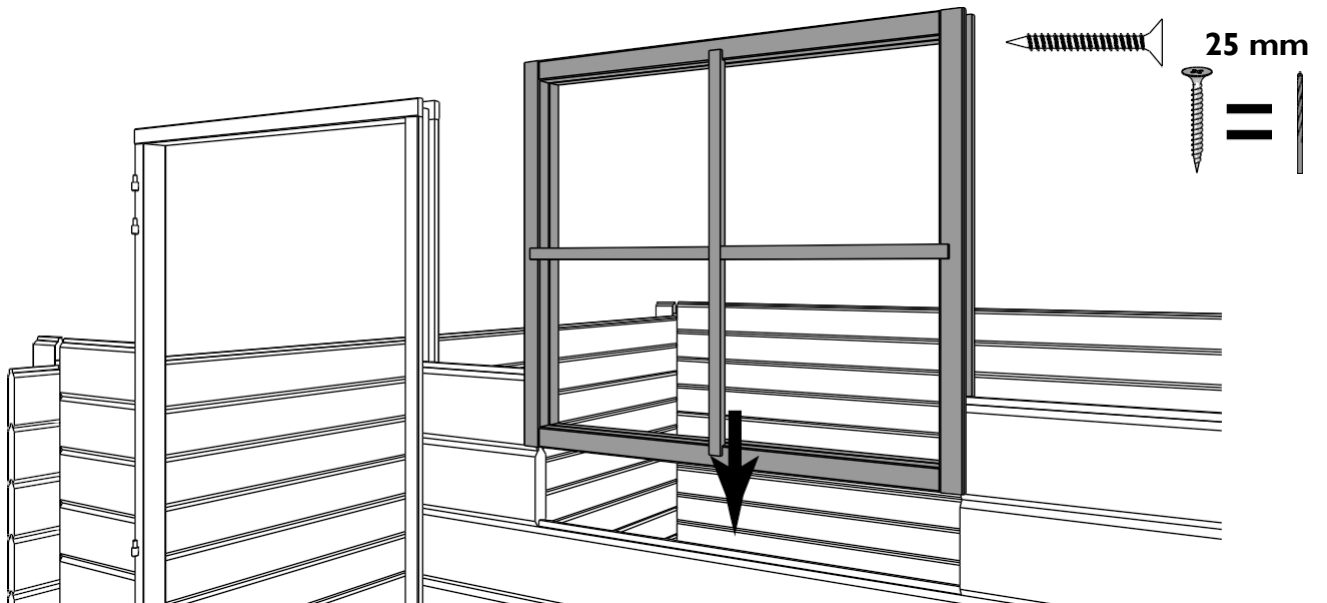

6.



7.

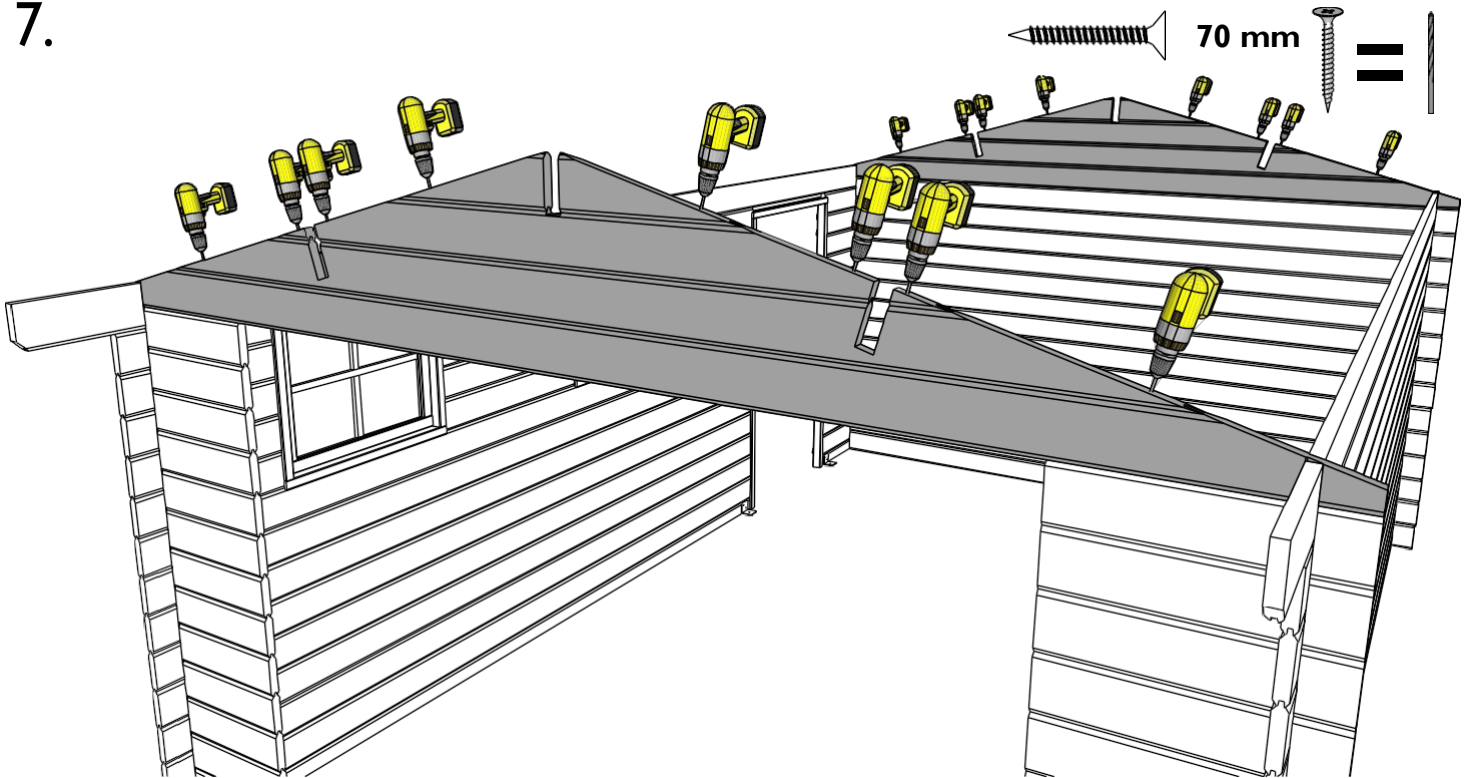

If there are height differences between the walls, check that the logs fit together properly. To compensate for a height difference (detail A), align the top log with the gable and screw them together (detail B). Now, gently tap the lower logs up one by one (detail C) to distribute the gap evenly across all logs (detail D).

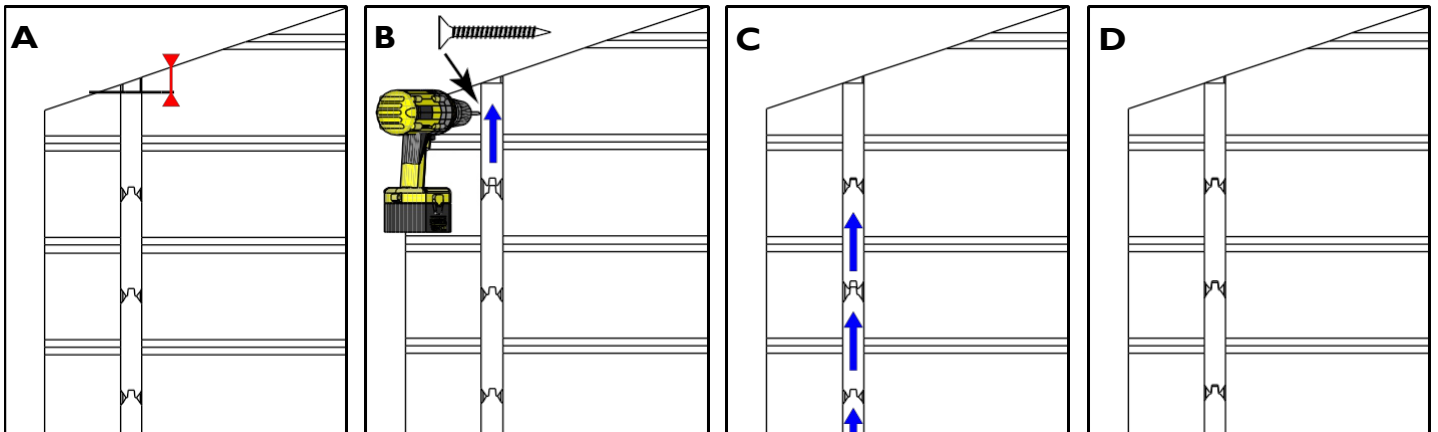

8. The number of roof rafters in this drawing may differ from the garage you have purchased. See parts list. Ensure that all roof rafters are flush with the overhang (log A5).

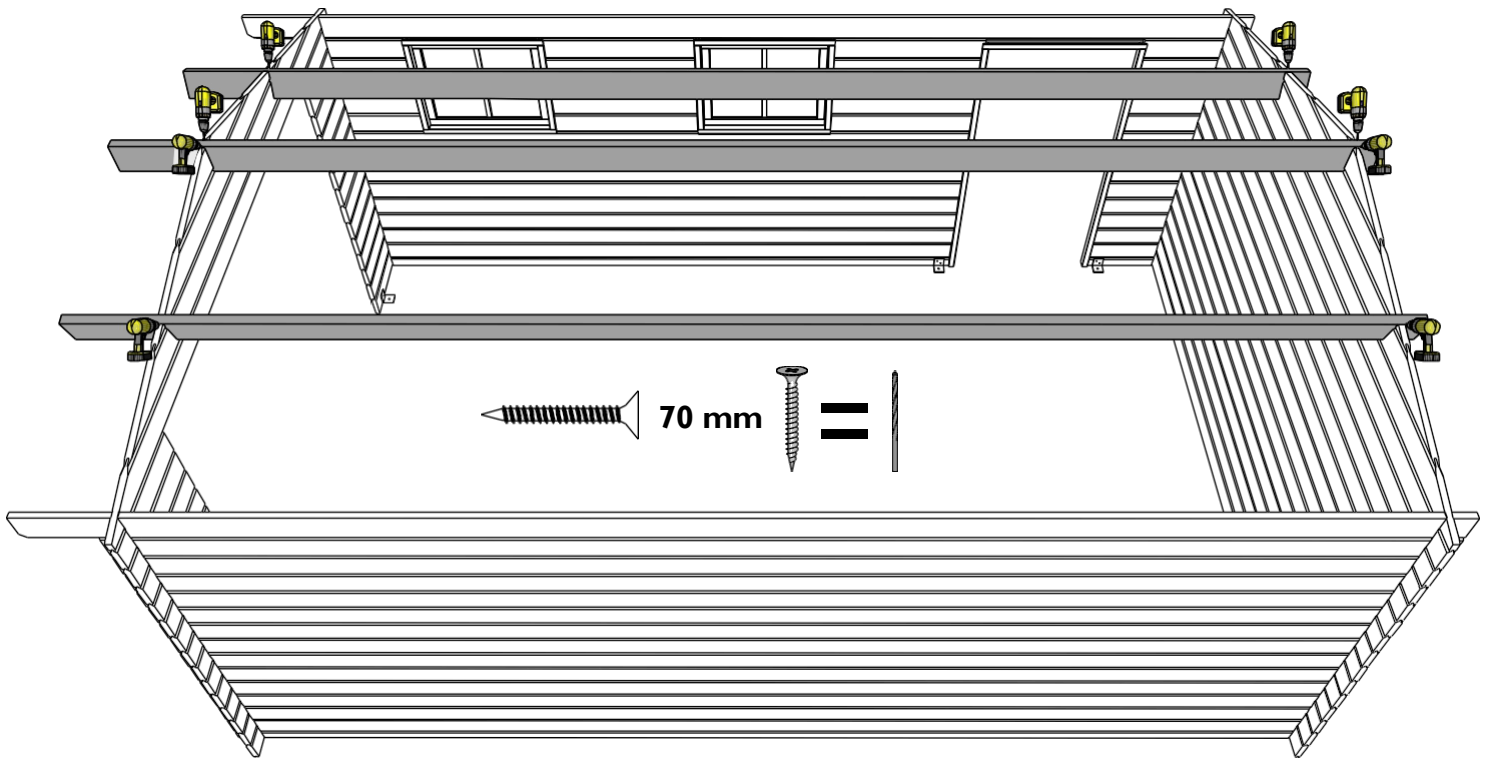

9. Place 4 temporary roof logs and nail them lightly so they can be adjusted later. Ensure the roof log overhangs evenly over the side wall everywhere. Now attach the side trim battens. These should protrude at the front as much as the roof rafters. Nail these lightly too, the ZSL batten serves as an alignment guide.

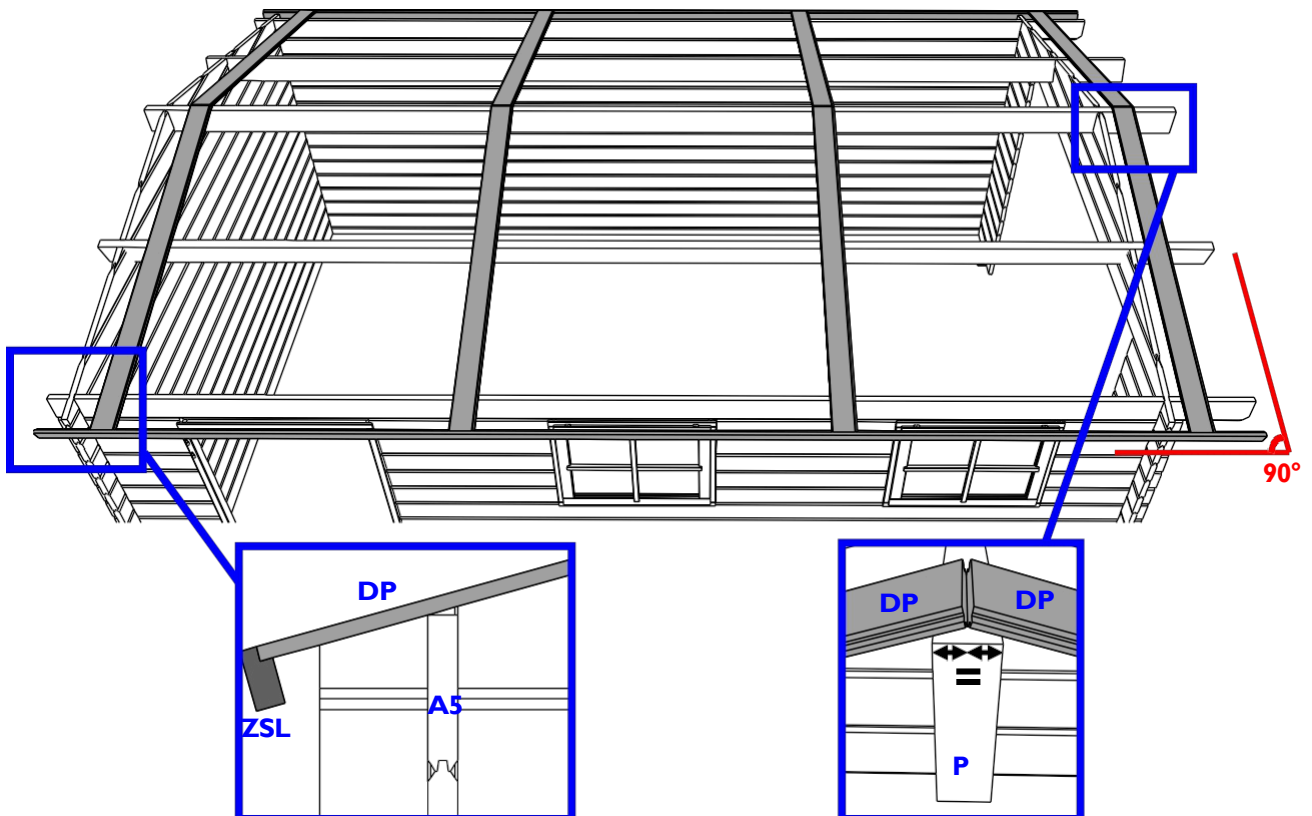

10. Place the first roof log at the front and nail it twice to each roof rafter and to the side wall. Also nail it to the side trim batten. When you reach the first temporary roof log, remove it and reposition it. Continue working towards the rear. If necessary, saw the last batten lengthwise. Finally, saw the ZSL at the rear to length.

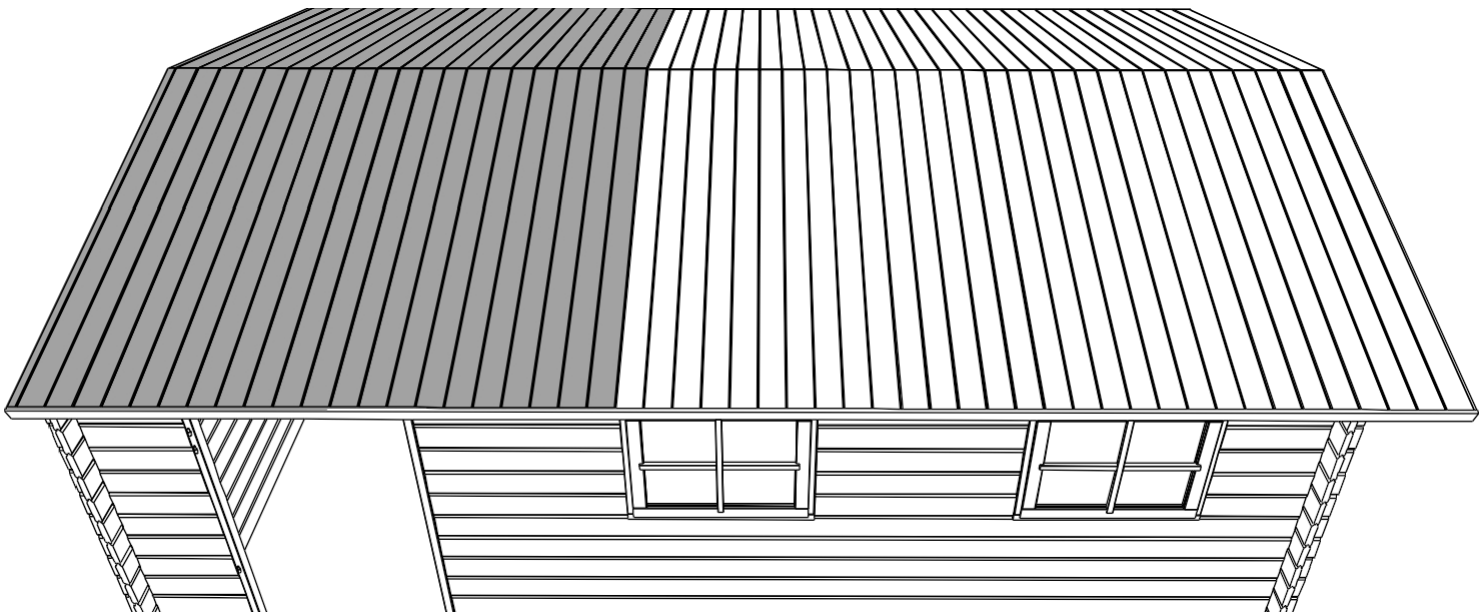
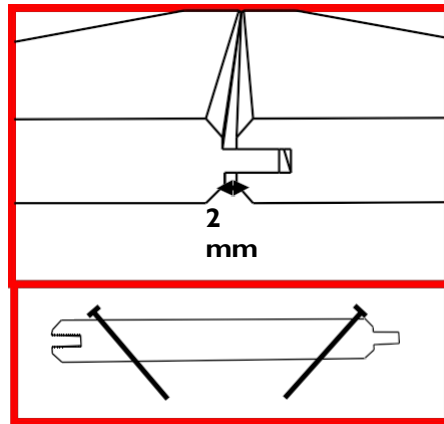
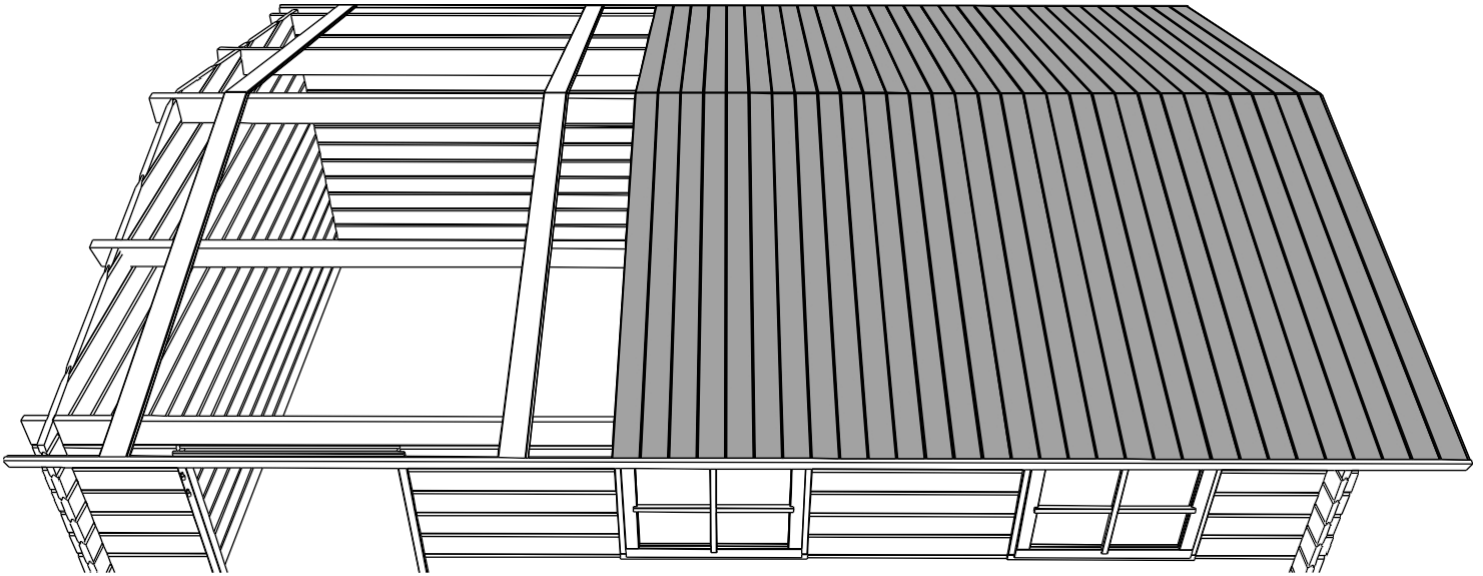

II

For models with shingles, please refer to point 12.

Cut the rolls of roofing to size (length) according to the parts list. Nail with shingle nails every 10 to 15 cm at the top and bottom of the sheet. Do not nail too deep, otherwise you risk water infiltration. To install the roofing sheets, start at the bottom and work your way up. Allow the bottom sheet to hang slightly over the ZSL, bending the roofing 5 cm over at the front and back. Apply the next strips, ensuring sufficient overlap with the previous strip. The roofing sheets that go over the roof ridge should overlap each other beyond the roof ridge. Depending on the model purchased, the number of sheets may differ from the drawings.

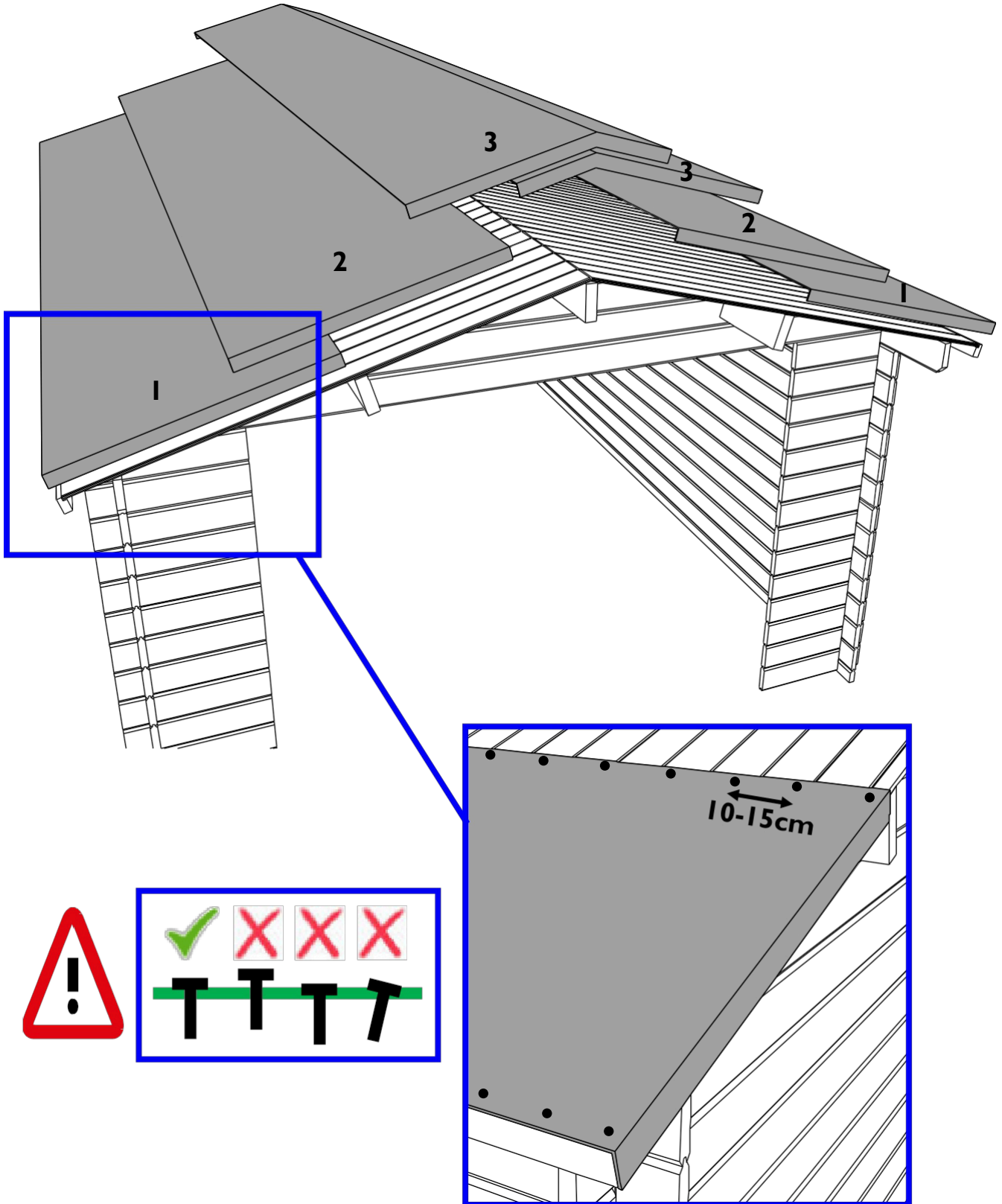

12.

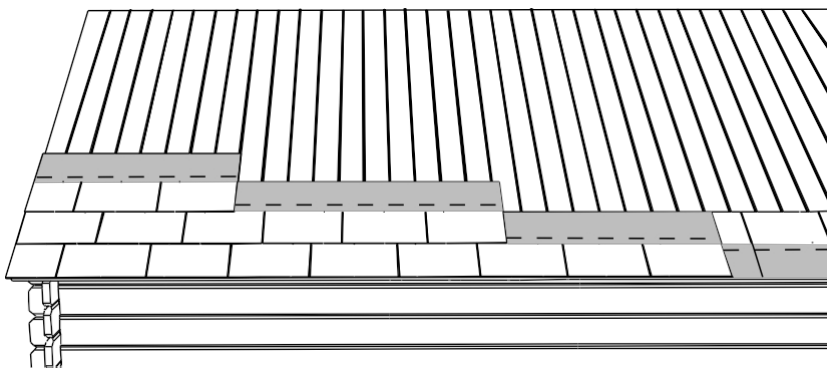
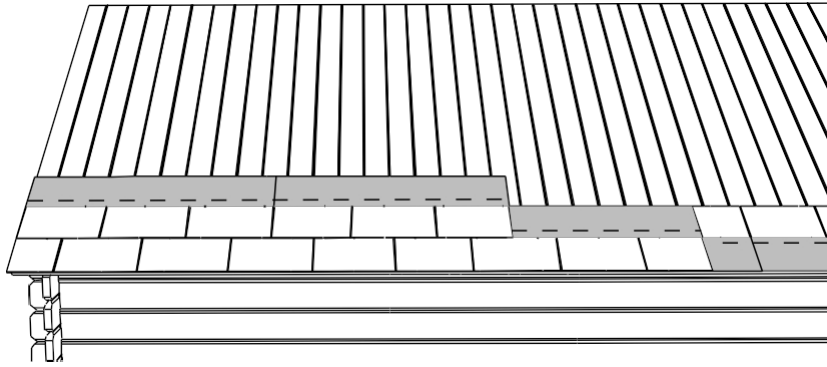
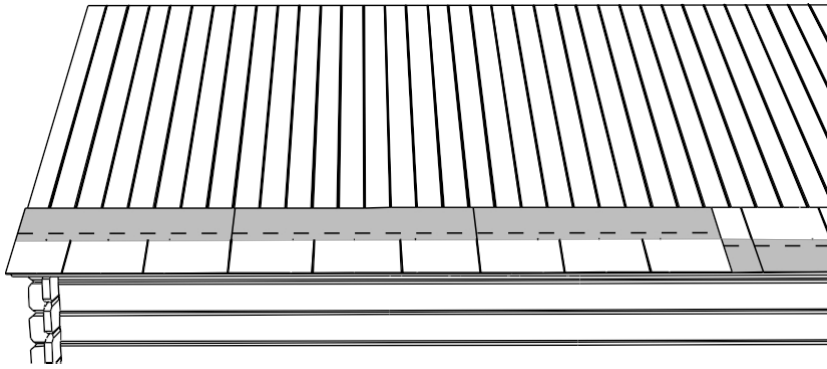
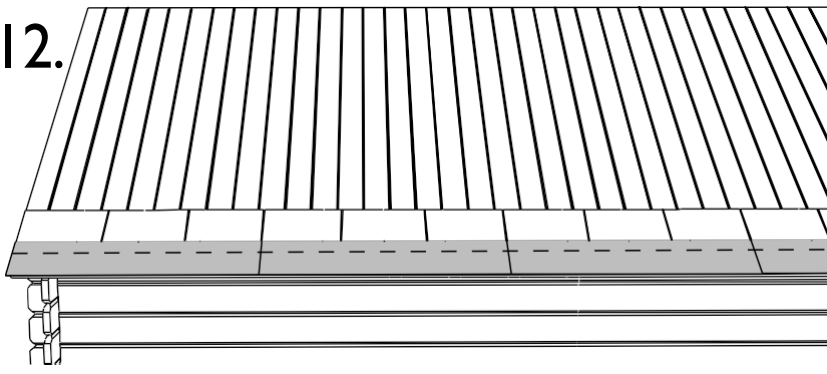

To install the shingles, start at the bottom and work your way up. Lay the first row of shingles with the cutouts facing upwards. Allow this first row to extend 3 cm beyond the edge of the roof. Nail only this row at the top and bottom, using 3 nails per shingle. Lay the next layers with the cutouts facing downwards. Nail 3 nails at the top of each shingle. The second layer should completely cover the first, but make sure that the cutouts are staggered. For the third layer, stagger the cutouts again. Continue in this way until you reach the top of the ridge line. At the front and rear of each row, cut the shingles flush with the roof logs. If this piece of waste is larger than 1 tab, you can use it to start the next layer.

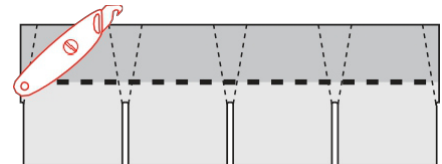

To cover the ridge, cut the shingles diagonally into pieces as shown in the drawing on the packs. Then lay these pieces overlapping each other. Take the direction of the storm wind into account when determining the direction in which you will overlap. Nail with 2 nails at the point where the next piece will overlap.

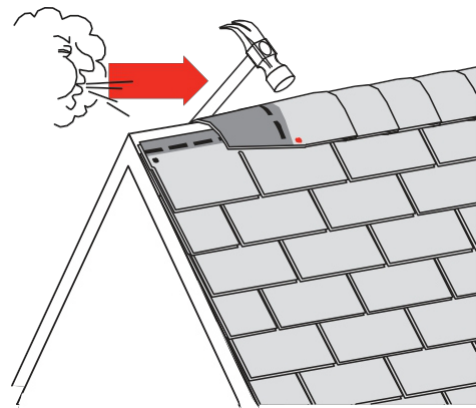

13.



4x

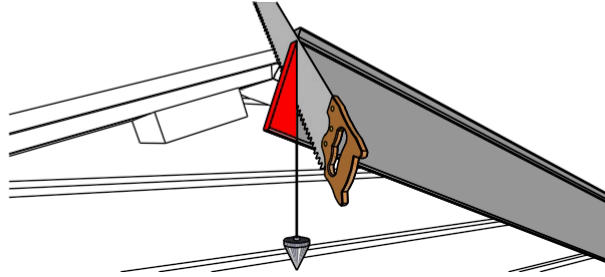
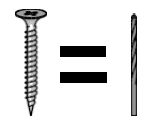
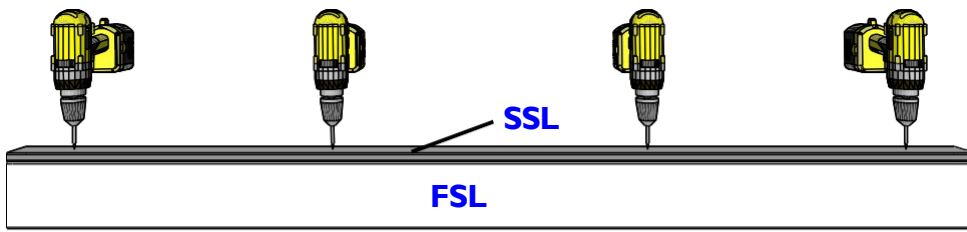

14

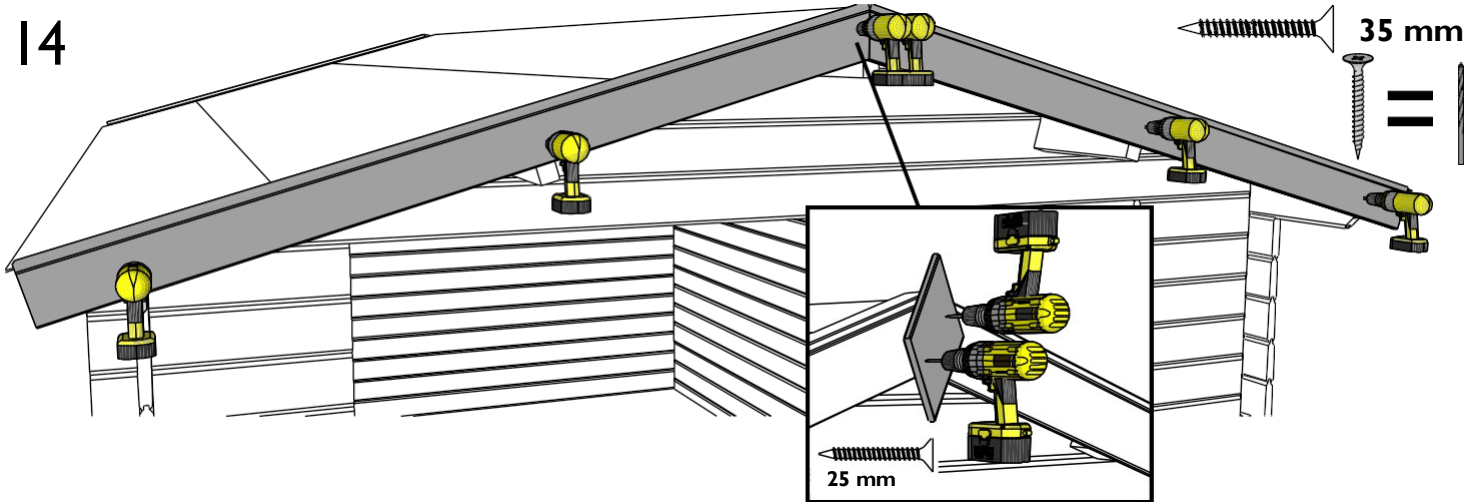

15.

Install the optional side door. Align by turning the hinges more or less. During the year, the door may no longer close properly. You can easily adjust it using the hinges.

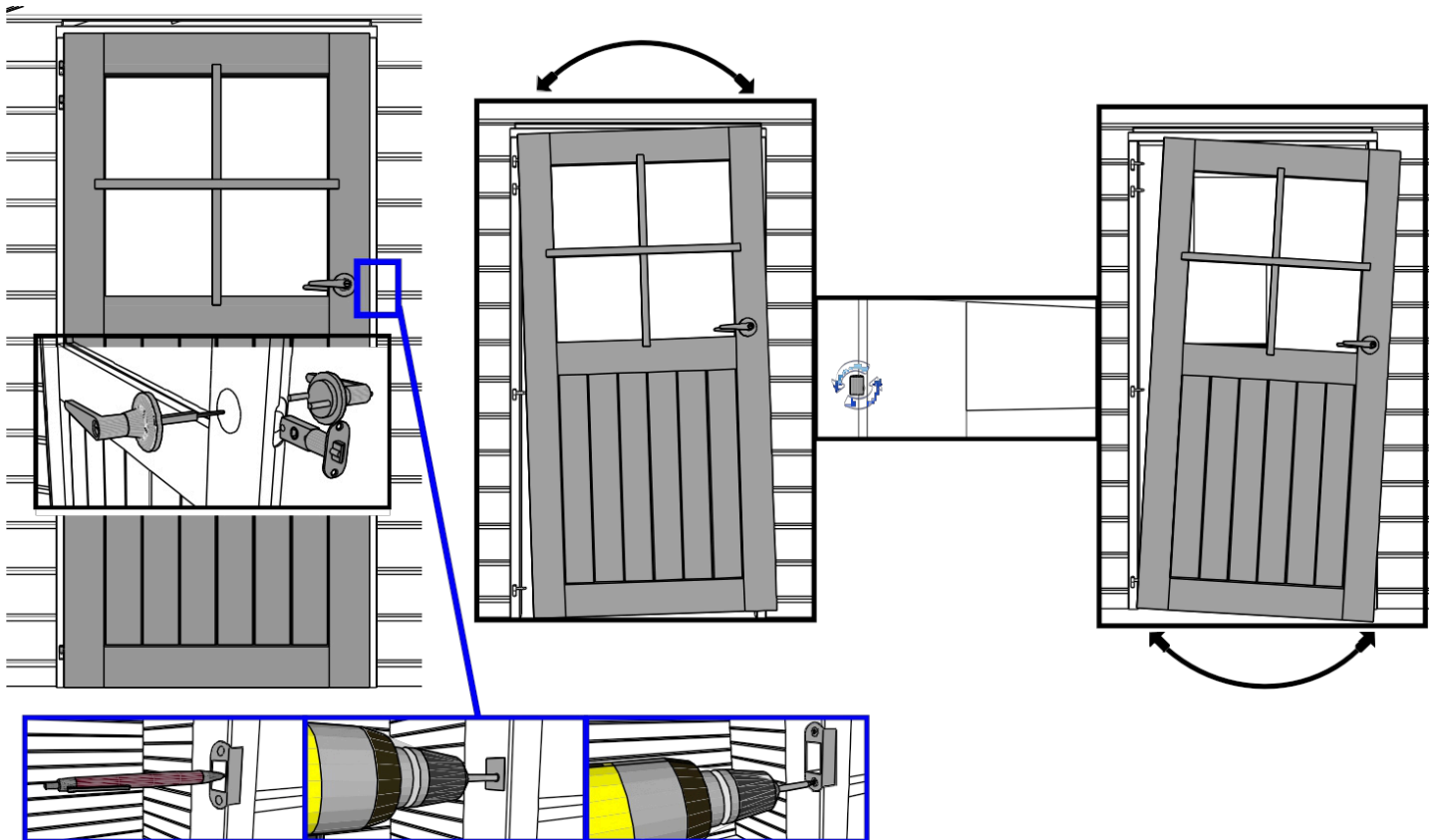

16.

Place the SRD trim battens above any windows and doors to cover the gap above the frame. Always screw them directly into the frame itself, never into the log above, so that your garage can still breathe.



35 mm

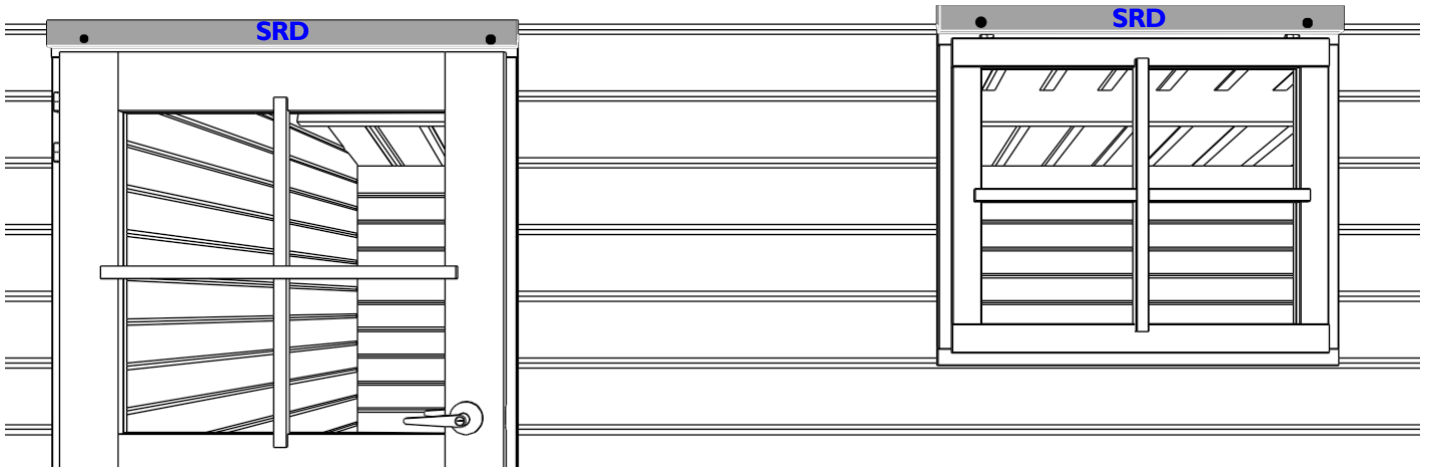
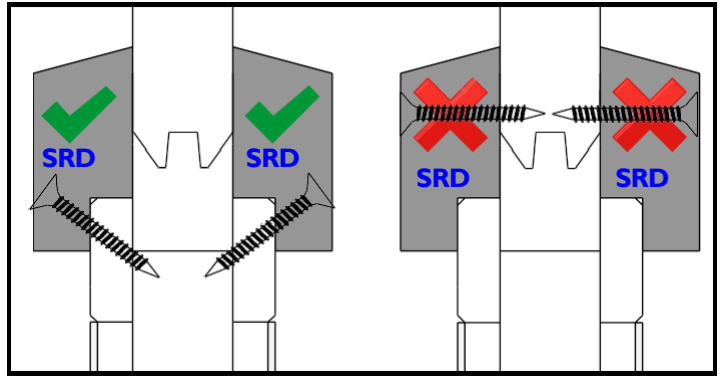
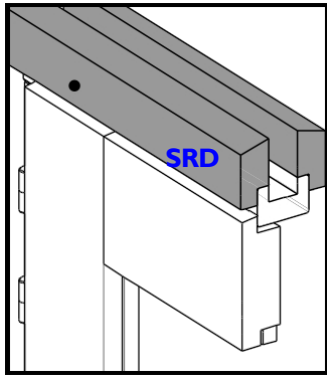
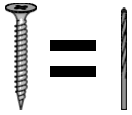

17.

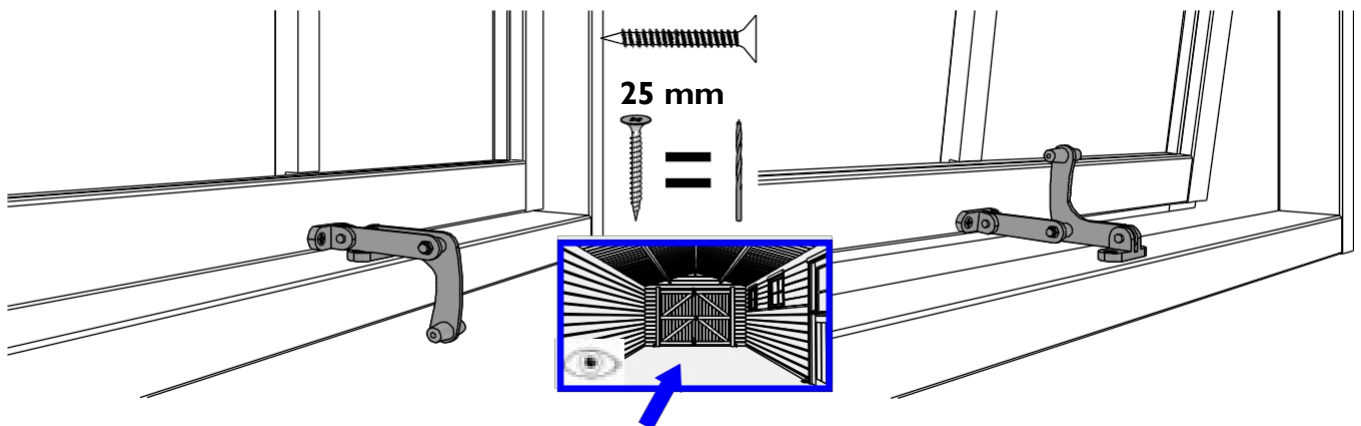

 Check the parts list to see which type of gate you have. Does your garage have a DDP01 gate? Then go to step 18a. If your garage has a DDP02 gate, go to step 18b.

18a.

Screw the gate posts only at the bottom into the wall log. Do not screw the frame anywhere else so that the wood can 'breathe'.

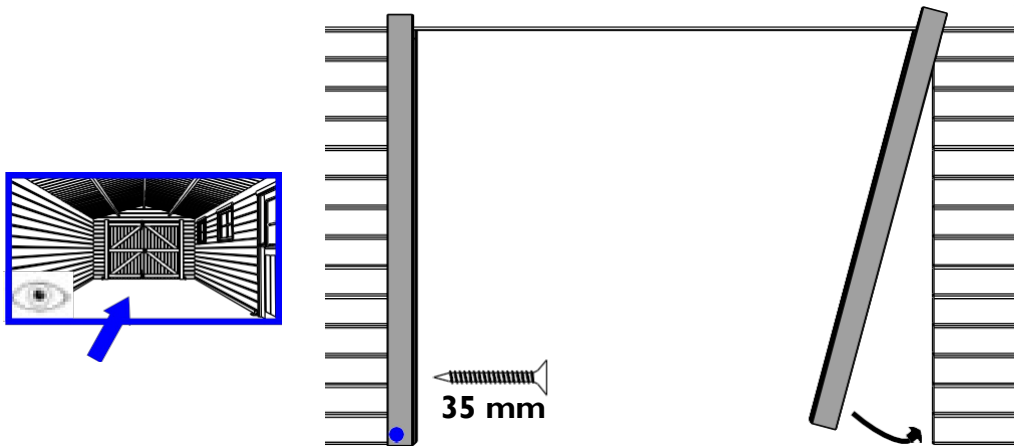

Place the lock in the recess provided and position the hinges at the height of the cross battens. Please refer to the instructions supplied with the lock for installation. Screw the M/1920 latch onto the outside of the gate with lock.

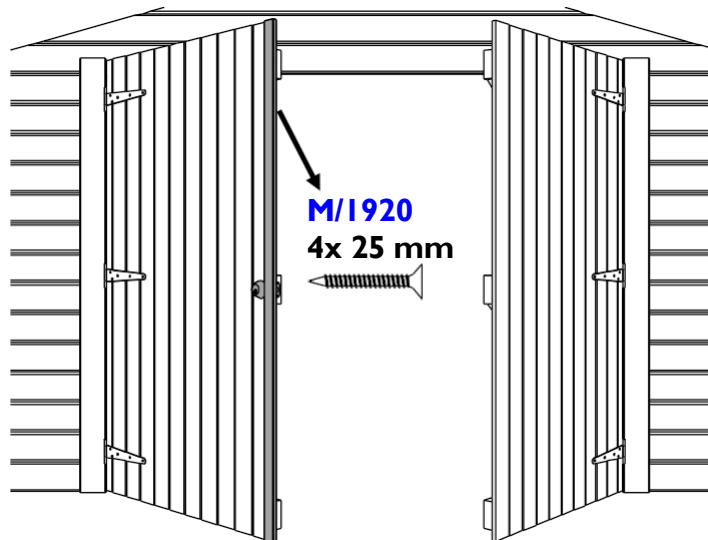

Place blocks on the left and right of the frame parts to secure the frame at the top and ensure that everything is aligned. Finally, attach the bolts to the gate without a lock.

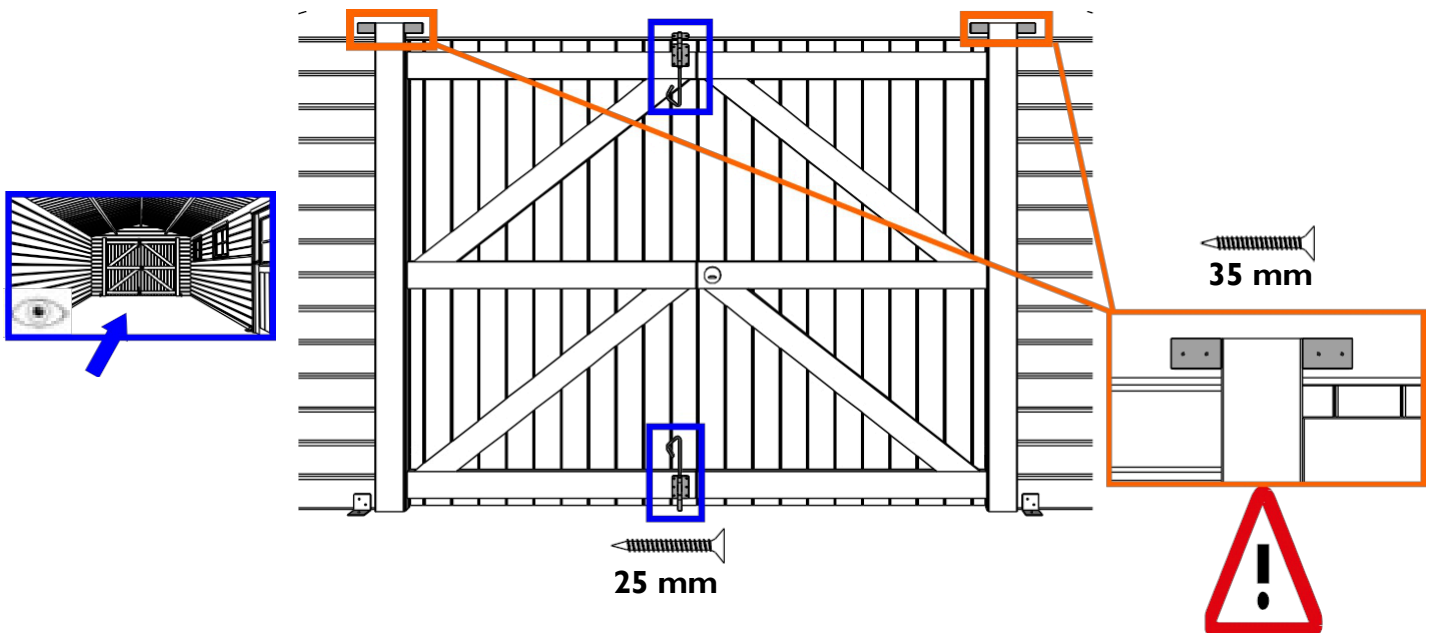

18b. Screw the gate posts at the bottom into the wall log. At the top, screw the frame parts together, but not into the wall logs.

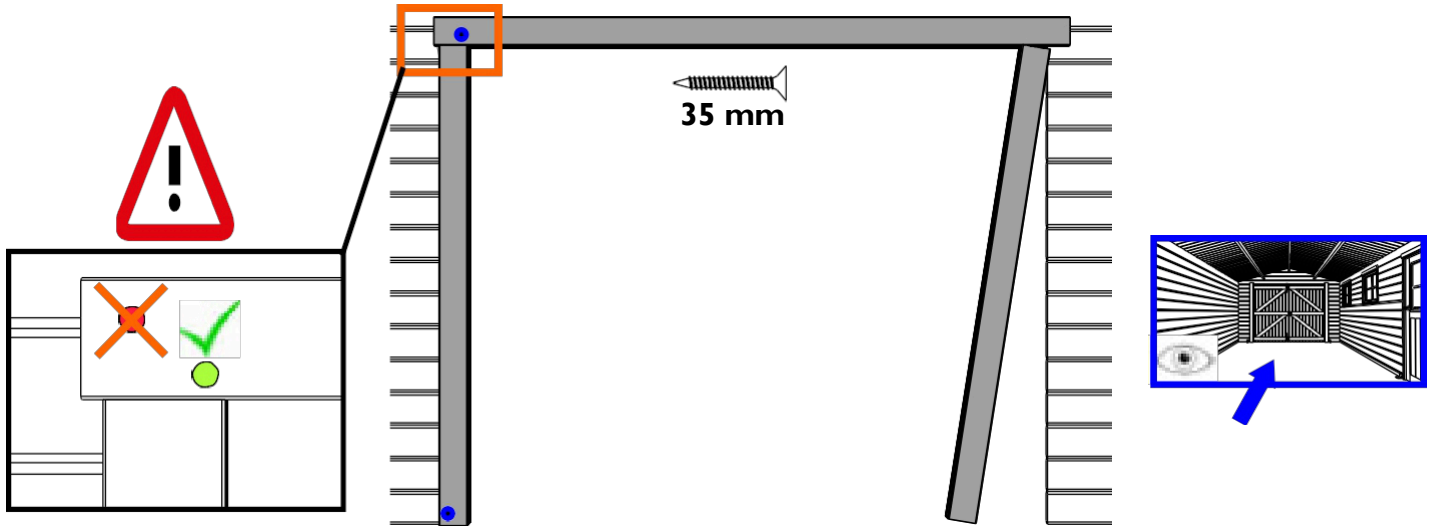

Place the lock in the recess provided and install the hinges. Please refer to the lock manual for installation instructions of the handle. Screw the M/1920 latch onto the outside of the gate with the handle.

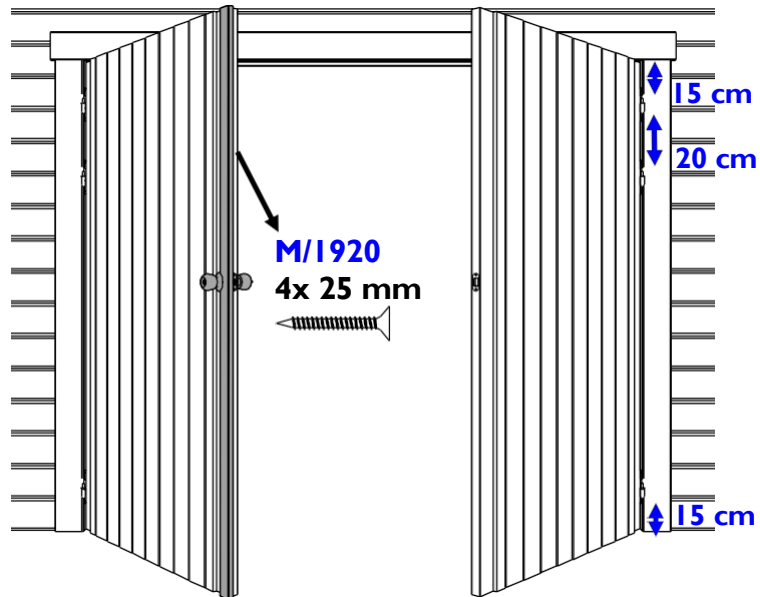

Place blocks on the left and right of the horizontal frame to secure it at the top. Attach the bolts to the gate without a handle. Finally, attach the striking plates to the frame on the inside against the gate with nails.

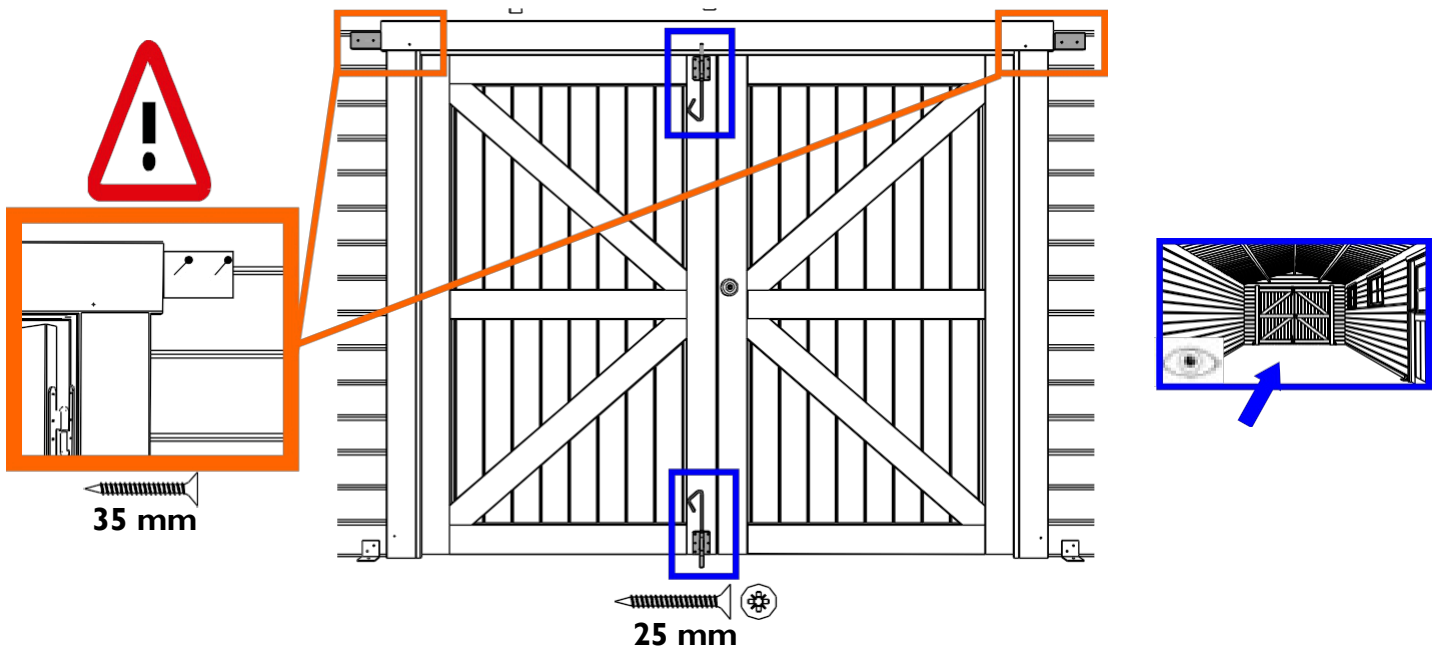

19.

Seal the following areas with silicone (not supplied):

- The joint between the garage and its base on the outside,
- Around the glass.

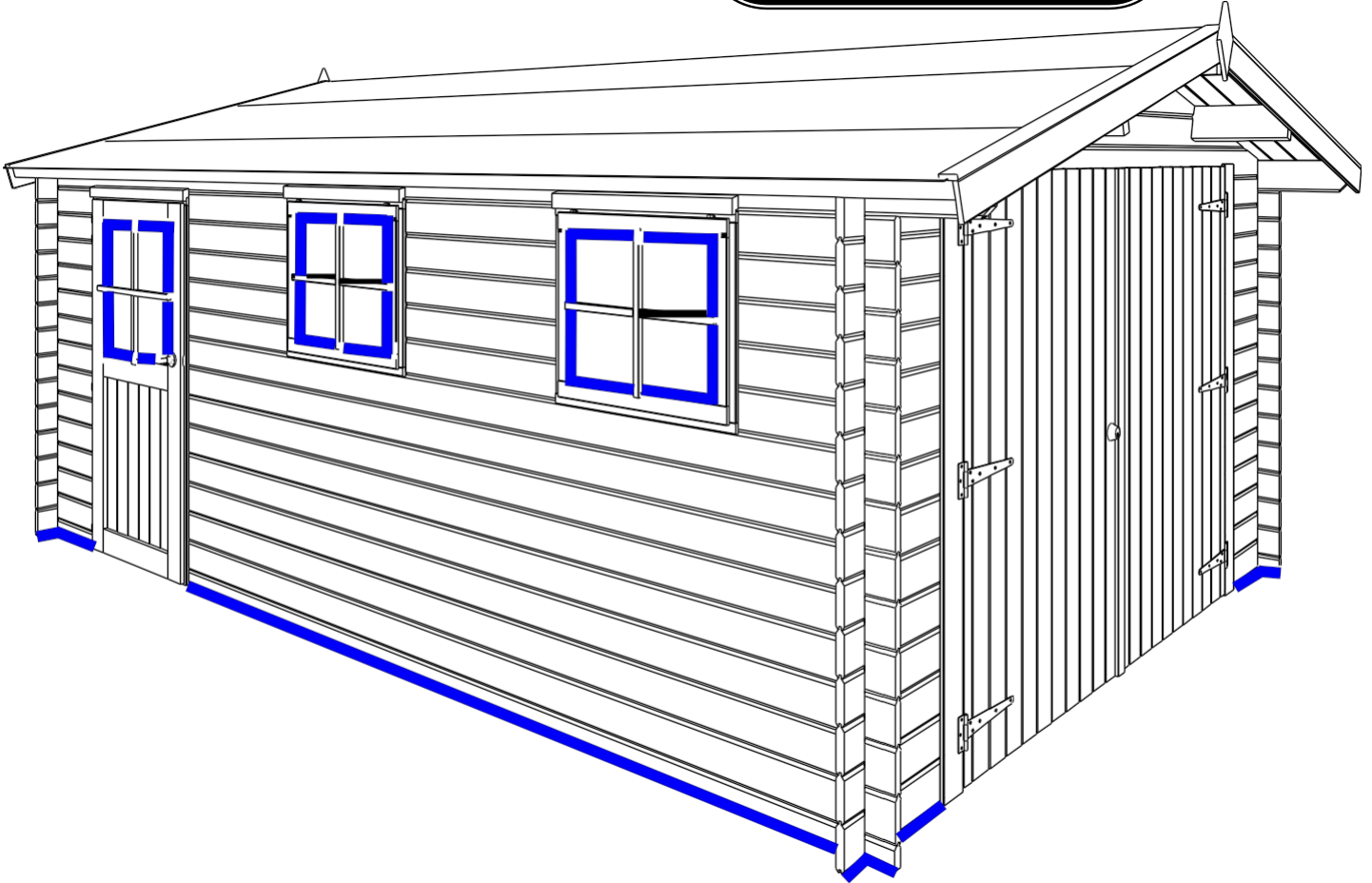

To make your garage storm-resistant, you will need to install storm bracing. This connects the roof and walls to the base. So make sure it is properly secured to the ground. Always ensure that you do not obstruct vertical shrinkage and expansion (see "wood lives"). Gardenas dealers sell our standard storm bracing. An alternative is to attach a screw to both the top and bottom logs and stretch a nylon cord between them. In any case, you must ensure that the force of the storm bracing does not cause the wall to bulge. If this is the case, you must adjust the bracing.

Maintenance: water, wind, snow and sun are your garage's worst enemies. Ask a specialist for advice if you have any questions about products, timing, etc. for treatment.

Product liability only applies if the garage has been assembled in full compliance with these assembly instructions.

WARRANTY

The product is made of wood, a natural product that, due to its outdoor placement, will continue to "live" and therefore requires ongoing attention. Assembly, treatment and anchoring will be carried out by or on behalf of the customer. Gardenas is therefore responsible for and provides a warranty on the product and its components themselves, but not for the consequences of incorrect assembly, missing or inadequate anchoring, or incorrect or inadequate maintenance.

How long?

Unless otherwise stated, Gardenas offers a 5-year warranty on its products. Fittings and roofing are covered by a 2-year warranty. Products sold as pressure-impregnated are covered by an extended 10-year warranty against rot, mould and insect damage to the wooden parts.

The warranty period starts from the date of purchase.

What is covered by the warranty?

- The structural design of the product for safe and normal use.
- The correctness of the parts in terms of quantity and shape upon delivery. Any deviations must be reported no later than 14 days after delivery.
- The warranty is limited to the replacement of defective, damaged or unusable parts.

What is not covered by the warranty?

- Costs of (re)installation, production, assembly, treatment.
- Parts that are no longer in their original condition.
- Defective parts that were installed anyway.
- Minor deviations from the natural material, whether or not specified in the manual, which do not compromise the stability and expected lifespan of the product (e.g. knots, cracks, discolouration, slight deformations that can be assembled and will have no impact after assembly or will be invisible after assembly, etc.).
- Damage, deformations or defects resulting from ignoring to strictly follow the advice and instructions in the product manual and/or incorrect or careless use of the product, as well as damage caused by poor foundations.
- Damage and degradation and their consequences due to inadequate treatment of the product.
- Damage caused during transport and storage, whether or not due to extreme humidity, if transport and storage were not carried out under Gardenas' management.
- Damage caused by third parties, animals, insects (except if the product was delivered pressure-impregnated) and termites.
- Natural ageing or discolouration of the product.
- Damage caused by a roof load (e.g. snow) of more than 50 kg/m².
- Direct or indirect damage to items and materials stored in or under the product.
- Consequences of force majeure: storms, natural disasters, floods, vandalism, etc.

Parts availability and delivery

Gardenas guarantees the availability of all parts or a valid alternative for each part for up to 5 years after purchase of the product, regardless of whether the part is still under warranty or not.

Gardenas will make every effort to provide any replacement parts as quickly as reasonably possible. Gardenas will deliver the parts in the same manner and to the same location as it delivered the original product.